

## L-Handle Combination Lock

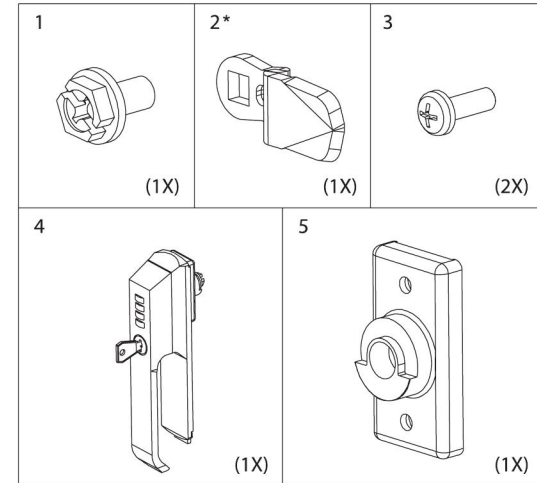
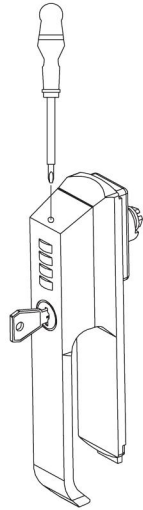

NOTE: Item 2 is not included with the kit.  
Please use the cam from the original latch.

The factory combination is set to "000" or "0000" and can be changed by following these steps:

1. Turn each wheel combination to show "0".
2. After wheels are showing a combination of "000" or "0000", use a sharp pointed device (small screwdriver, nail or other device) to press the small round hole located above the combination wheels. Upon insertion, the round hole will move inward.
3. While maintaining pressure on the round hole, turn the combination wheels to the desired numbers. Release pressure of the sharp pointed device. The combination has now been changed.
4. Record the new combination on paper and store in a secure location. **To access or to change the combination, it must be known.**

### Resetting the combination:

Use the same steps outlined above, but use the current combination instead of the factory set combination of "000" or "0000".

Note: Always record (electronically or on paper) the combination and store in an accessible secure location. It will be needed for access and for any future combination changes.

